

SATEL

Mission-Critical Connectivity

SATEL Proof-TR489

SATEL Proof-TR4+

SATEL Proof-TR9

SATEL Proof-R4+

**Radio Modem
User Guide**



TABLE OF CONTENTS

TABLE OF CONTENTS	2
IMPORTANT NOTICE	4
RESTRICTIONS ON USE – SATEL PROOF-TR4+/R4+.....	5
RESTRICTIONS ON USE – SATEL PROOF-TR9	6
RESTRICTIONS ON USE – SATEL PROOF-TR489	8
PRODUCT CONFORMITY.....	11
WARRANTY AND SAFETY INSTRUCTIONS	12
1 DESCRIPTION OF THE PRODUCT	13
2 SATEL PROOF-TR4+/R4+ TECHNICAL SPECIFICATIONS.....	14
3 SATEL PROOF-TR9 TECHNICAL SPECIFICATIONS.....	17
4 SATEL PROOF-TR489 TECHNICAL SPECIFICATIONS.....	18
5 CONFIGURATION	23
5.1 SATEL NETCO DEVICE software	23
5.2 Configuration Manager software	23
5.3 Changing parameters using SL commands.....	25
6 SERIAL INTERFACE	27
6.1 Pause length	27
6.2 Data buffering.....	28
7 MODEM SETTINGS.....	29
8 CONNECTORS	33
8.1 Antenna connector.....	33
8.2 Power/Data connector	33
9 RF INTERFACE	34
9.1 Transmitter.....	34
9.2 Receiver.....	35

9.3	Encryption.....	36
9.4	Radio state	36
9.5	Priority RX/TX.....	37
9.6	Forward Error Correction (FEC)	37
9.7	Error checking	37
9.8	TX delay	38
9.9	Add RSSI to data	38
9.10	Separate RX/TX-frequencies.....	38
9.11	Call Sign	38
9.12	Channel list	39
9.13	Repeater mode.....	40
9.14	Radio compatibility	42
10	TEST MODES	47
10.1	Short Block Test.....	47
10.2	Long Block Test	47
11	MECHANICAL DIMENSIONS	48
12	INSTALLATION.....	49
13	GROUNDING.....	50
14	ACCESSORIES	51
15	PROPOSALS FOR MORE RELIABLE RADIO LINK	52
16	APPENDIX A – TRANSMISSION DELAYS	53

IMPORTANT NOTICE

All rights to this manual are owned solely by SATEL Oy (referred to in this user guide as SATEL). All rights reserved. The copying of this manual (without the written permission from the owner) by printing, copying, recording or by any other means, or the full or partial translation of the manual to any other language, including all programming languages, using any electrical, mechanical, magnetic, optical, manual or other methods or devices is forbidden.

SATEL reserves the right to change the technical specifications or functions of its products, or to discontinue the manufacture of any of its products or to discontinue the support of any of its products, without any written announcement and urges its customers to ensure, that the information at their disposal is valid.

SATEL software and programs are delivered "as is". The manufacturer does not grant any kind of warranty including guarantees on suitability and applicability to a certain application. Under no circumstances is the manufacturer or the developer of a program responsible for any possible damages caused by the use of a program. The names of the programs as well as all copyrights relating to the programs are the sole property of SATEL. Any transfer, licensing to a third party, leasing, renting, transportation, copying, editing, translating, modifying into another programming language or reverse engineering for any intent is forbidden without the written consent of SATEL.

SATEL PRODUCTS HAVE NOT BEEN DESIGNED, INTENDED NOR INSPECTED TO BE USED IN ANY LIFE SUPPORT RELATED DEVICE OR SYSTEM RELATED FUNCTION NOR AS A PART OF ANY OTHER CRITICAL SYSTEM AND ARE GRANTED NO FUNCTIONAL WARRANTY IF THEY ARE USED IN ANY OF THE APPLICATIONS MENTIONED.

Salo, FINLAND 2025

RESTRICTIONS ON USE – SATEL Proof-TR4+/R4+

SATEL Proof-TR4+ and SATEL Proof-R4+ radio modems have been designed to operate on 403-473 MHz frequency band, the exact use of which differs from one region and/or country to another. The user of a radio modem must take care that the said device is not operated without the permission of the local authorities on frequencies other than those specifically reserved and intended for use without a specific permit.

This device complies with part 15 of the FCC Rules. Operation is subject to the following two conditions: (1) This device may not cause harmful interference, and (2) this device must accept any interference received, including interference that may cause undesired operation.

Modification warning statement

Changes or modifications not expressly approved by the party responsible for compliance could void the user's authority to operate the equipment.

SATEL Proof-TR4+/R4+ are allowed to be used in the following countries, either on license free channels or on channels where the operation requires a license. More detailed information is available at the local frequency management authority.

Countries: AT, AU, BE, BG, BR, CA, CH, CY, CZ, DE, DK, EE, ES, FI, FR, GB, GR, HU, HR, IE, IS, IT, LT, LU, LV, MT, NL, NO, PL, PT, RO, SE, SI, SK, TR, US

WARNING! Users of **SATEL Proof-TR4+** radio modem in North America should be aware, that due to the allocation of the frequency band 406.0 – 406.1 MHz for government use only, the use of radio transceiver on this frequency band without a proper permit is strictly forbidden.



WARNING - RF Exposure!

To comply with CE, FCC and IC RF exposure compliance requirements the maximum antenna gain is 14 dBi and **the minimum separation distance (listed in the table below)** must be maintained between the antenna of SATEL Proof-TR4+ and all persons.

<i>Antenna Gain [dBi]</i>	<i>Separation distance [cm]</i>
0	23
4	36
6	45
8	56
10	71
12	89
14	112

RESTRICTIONS ON USE – SATEL Proof-TR9

SATEL Proof-TR9 radio modem has been designed to operate on 902-928 MHz frequency band, the exact use of which differs from one region and/or country to another. The user of a radio modem must take care that the said device is not operated without the permission of the local authorities on frequencies other than those specifically reserved and intended for use without a specific permit.

This device complies with part 15 of the FCC Rules. Operation is subject to the following two conditions: (1) This device may not cause harmful interference, and (2) this device must accept any interference received, including interference that may cause undesired operation.

Modification warning statement

Changes or modifications not expressly approved by the party responsible for compliance could void the user's authority to operate the equipment.

SATEL Proof-TR9 is allowed to be used in the following countries. More detailed information is available at the local frequency management authority.

Countries: AU, BR, CA, US

The frequency band in USA and Canada is 902 – 928 MHz. In Australia and Brazil the frequency band is limited to 915 – 928 MHz due to the local regulations. SATEL provides the specific product variants that are configured for the specific regions.



WARNING - RF Exposure!

To satisfy FCC and ISED RF exposure requirements for mobile transmitting devices, a **separation distance of 35 cm or more** must be maintained between antenna of SATEL Proof-TR9 and persons during device operation. To ensure compliance, operations at closer than this distance is not recommended. The antenna used for this transmitter must not be co-located in conjunction with any other antenna or transmitter. FCC regulations allow up to 36 dBm equivalent isotropically radiated power (EIRP). Therefore, the sum of the transmitted power (in dBm), the cabling loss and the antenna gain cannot exceed 36 dBm.

This device contains the radio transmitter module that has been approved by Federal Communications Commission (FCC ID: MRBSATEL-TA31) and Innovation, Science and Economic Development (ISED) Canada (IC: 2422A-SATELTA31) to operate with the antenna types listed below with the maximum permissible gain indicated. Antenna types not included in this list,

having a gain greater than the maximum gain indicated for that type, are strictly prohibited for use with this device.

<i>Antenna type</i>	<i>Manufacturer</i>	<i>Antenna model</i>	<i>Maximum gain (dBi)</i>
Omnidirectional	Oy CompleTech Ltd	CA915H	5
Directional (yagi)	Oy CompleTech Ltd	CA930Y	6

This device contains licence-exempt transmitter(s)/receiver(s) that comply with Innovation, Science and Economic Development Canada's licence-exempt RSS(s) and part 15 of the FCC Rules. Operation is subject to the following two conditions:

1. This device may not cause interference.
2. This device must accept any interference, including interference that may cause undesired operation of the device.

L'émetteur/récepteur exempt de licence contenu dans le présent appareil est conforme aux CNR d'Innovation, Sciences et Développement économique Canada applicables aux appareils radio exempts de licence. L'exploitation est autorisée aux deux conditions suivantes :

1. L'appareil ne doit pas produire de brouillage;
2. L'appareil doit accepter tout brouillage radioélectrique subi, même si le brouillage est susceptible d'en compromettre le fonctionnement.

RESTRICTIONS ON USE – SATEL Proof-TR489

SATEL Proof-TR489 radio modems have been designed to operate on the following frequency bands, the exact use of which differs from one region and/or country to another:

- 403-473 MHz (licenced frequencies in most countries)
- 869.4-869.65 MHz (the pan-European licence-free frequency band as defined by the European Conference of Postal and Telecommunications Administrations CEPT/ERC/REC 70-03 recommendation relating to the use of Short Range Devices (SRD))
- 902-928 MHz (licence-free ISM frequency band in USA and Canada)

The user of a radio modem must take care that the said device is not operated without the permission of the local authorities on frequencies other than those specifically reserved and intended for use without a specific permit in each specific country. For example, the use of 869.4-869.65 MHz frequency band is strictly forbidden in North America. Likewise, the use of 902-928 MHz frequency band is forbidden in Europe.

This device complies with part 15 of the FCC Rules. Operation is subject to the following two conditions: (1) This device may not cause harmful interference, and (2) this device must accept any interference received, including interference that may cause undesired operation.

Modification warning statement:

Changes or modifications not expressly approved by the party responsible for compliance could void the user's authority to operate the equipment.

Restrictions on use - 403-473 MHz frequency band:

SATEL Proof-TR489 radio modems (on 403-473 MHz band) are allowed to be used in the following countries, either on license free channels or on channels where the operation requires a license. More detailed information is available at the local frequency management authority.

Countries: AT, AU, BE, BG, CA, CH, CY, CZ, DE, DK, EE, ES, FI, FR, GB, GR, HU, HR, IE, IS, IT, LT, LU, LV, MT, NL, NO, PL, PT, RO, SE, SI, SK, TR, US

WARNING! Users of **SATEL Proof-TR489** radio modems in North America should be aware, that due to the allocation of the frequency band 406.0 – 406.1 MHz for government use only, the use of radio transceiver on this frequency band without a proper permit is strictly forbidden.



WARNING - RF Exposure!

To comply with CE, FCC and IC RF exposure compliance requirements the maximum antenna gain is 14 dBi and **the minimum separation distance (listed in the table below)** must be maintained between the antenna of SATEL Proof-TR489 and all persons when transmitting on 403-473 MHz frequency band.

<i>Antenna Gain [dBi]</i>	<i>Separation distance [cm]</i>
0	23
4	36
6	45
8	56
10	71
12	89
14	112

Restrictions on use – 869.4-869.65 MHz frequency band:

SATEL Proof-TR489 radio modems (on 869.4-869.65 MHz band) are allowed to be used in the following countries, either on license free channels or on channels where the operation requires a license. More detailed information is available at the local frequency management authority.

Countries: AT, BE, BG, CH, CY, CZ, DE, DK, EE, ES, FI, FR, GB, GR, HU, HR, IE, IS, IT, LT, LU, LV, MT, NL, NO, PL, PT, RO, SE, SI, SK, TR

NOTE: The following restrictions apply to the pan-European licence-free 869.4-869.65 MHz frequency band:

- The maximum allowed transmitted power from the antenna is 500 mW ERP (Effective Radiated Power relative to a half-wave dipole antenna in any certain direction) - in other words, the antenna gain must NOT exceed the signal loss of the antenna cable in case the transmitter power is set to 500 mW
- The maximum allowed duty cycle of the transmission is 10% (internally limited by the radio modem)



WARNING - RF Exposure!

The minimum separation distance of 25 cm must be maintained between the antenna of SATEL Proof-TR489 and all persons when transmitting on 869.4-869.65 MHz frequency band.

Restrictions on use - 902-928 MHz frequency band:

SATEL Proof-TR489 radio modems (on 902-928 MHz band) are allowed to be used in the following countries. More detailed information is available at the local frequency management authority.

Countries: AU, CA, US

The frequency band in USA and Canada is 902 – 928 MHz. In Australia the frequency band is limited to 915 – 928 MHz due to the local regulations. SATEL provides the specific product variants that are configured for the specific regions.



WARNING - RF Exposure!

To satisfy FCC and ISED RF exposure requirements for mobile transmitting devices, **a separation distance of 35 cm or more** must be maintained between antenna of this device and persons during device operation when transmitting on 902-928 MHz frequency band.

This device contains the radio transmitter module that has been approved by Federal Communications Commission (FCC ID: MRBSATEL-TA43) and Innovation, Science and Economic Development (ISED) Canada (IC: 2422A-SATELTA43) to operate with the antenna types listed below with the maximum permissible gain indicated. Antenna types not included in this list, having a gain greater than the maximum gain indicated for that type, are strictly prohibited for use with this device.

Antenna type	Manufacturer	Antenna model	Maximum gain (dBi)
Omnidirectional (whip)	Laird Connectivity	FG9026	6
Directional (yagi)	PulseLarsen Antennas	YA6900W	6

This device contains licence-exempt transmitter(s)/receiver(s) that comply with Innovation, Science and Economic Development Canada's licence-exempt RSS(s) and part 15 of the FCC Rules. Operation is subject to the following two conditions:

1. This device may not cause interference.
2. This device must accept any interference, including interference that may cause undesired operation of the device.

L'émetteur/récepteur exempt de licence contenu dans le présent appareil est conforme aux CNR d'Innovation, Sciences et Développement économique Canada applicables aux appareils radio exempts de licence. L'exploitation est autorisée aux deux conditions suivantes :

1. L'appareil ne doit pas produire de brouillage;
2. L'appareil doit accepter tout brouillage radioélectrique subi, même si le brouillage est susceptible d'en compromettre le fonctionnement.

PRODUCT CONFORMITY

Under the sole responsibility of manufacturer SATEL Oy declares that SATEL Proof-TR4+, SATEL Proof-R4+, SATEL Proof-TR489 radio modems are in compliance with the essential requirements (radio performance, electromagnetic compatibility and electrical safety) and other relevant provisions of Directives 2014/53/EU and 2011/65/EU and Council recommendation 1999/519/EC. Therefore, the equipment is labelled with the following CE-marking. The operating frequency range of the device is not harmonized throughout the market area, and the local spectrum authority should be contacted before the usage of the radio modem.



WARRANTY AND SAFETY INSTRUCTIONS

Read these safety instructions carefully before using the product:

- Warranty will be void, if the product is used in any way that is in contradiction with the instructions given in this manual, or if the radio modem housing has been opened or tampered with.
- The radio modem is only to be operated at frequencies allocated by local authorities, and without exceeding the given maximum allowed output power ratings. SATEL and its distributors are not responsible, if any products manufactured by it are used in unlawful ways.
- The devices mentioned in this manual are to be used only according to the instructions described in this manual. Faultless and safe operation of the devices can be guaranteed only if the transport, storage, operation and handling of the devices is appropriate. This also applies to the maintenance of the products.
- To prevent damage both the radio modem and any terminal devices must always be switched OFF before connecting or disconnecting the serial connection cable. It should be ascertained that different devices used have the same ground potential. Before connecting any power cables, the output voltage of the power supply should be checked.
- Any radio link can be susceptible to external interference and signal degradation by its nature. Because of that, the effects of possible interference mechanisms and the sufficient back-up schemes must be taken into account in the system design of the critical applications.

NOTE!

When selecting a suitable location for the radio modem it must be ensured that the radio modem is not installed underwater. Direct sunlight is also to be avoided. It is not recommendable to install the radio modem on a strongly vibrating surface. Suitable dampening and/or isolation materials should be used in cases where the installation surface will be subjected to vibration.

1 DESCRIPTION OF THE PRODUCT

SATEL Proof radio modems are UHF radio transceivers that provide a transparent data link with many SATEL serial radios and with many other manufacturers' radio modems.

- **SATEL Proof-TR4+** supports 403...473 MHz frequency band
- **SATEL Proof-R4+** is the receiver only variant of SATEL Proof-TR4+
- **SATEL Proof-TR9** supports 902...928 MHz frequency band
- **SATEL Proof-TR489** supports the following frequency bands:
 - 403...473 MHz
 - 869.4...869.65 MHz
 - 902...928 MHz

SATEL Proof radio modems can be connected to various communication devices via RS-232 serial data interface. The Deutsch DT series connector provides the pins for data lines (TD, RD) and power supply (+7...+27.5 VDC). Antenna is connected to the female TNC connector.

SATEL Proof-TR4+/R4+/TR9/TR489 are heavy-duty radio modems that meet the requirements of machine control, smart farming and marine applications. They are built to last dirt, vibration, sand, dust, liquids and lightning:

- SATEL Proof radio modems have a profound electrical protection - both the power and data lines as well as the antenna interface are surge protected.
- SATEL Proof radio modems are IP67/IP69K rated against ingress of dust and high temperature, high pressure water. See more detailed description on chapter "Technical Specifications"
- Additionally, SATEL Proof radio modems provide RF filtering on GNSS frequencies to work seamlessly in GNSS positioning applications.

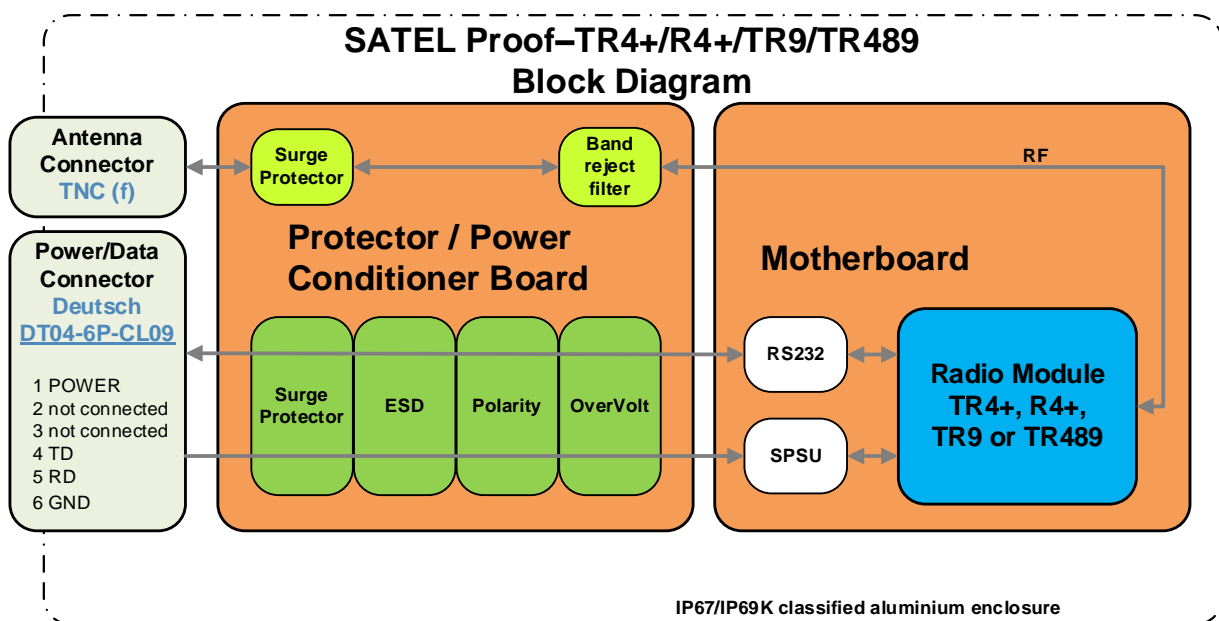

2 SATEL Proof-TR4+/R4+ TECHNICAL SPECIFICATIONS

SATEL Proof-TR4+/R4+ comply with the following international standards:

- EN 300 113 (radio)
- EN 301 489-1, EN 301 489-5 (EMC)
- IEC 62368-1 (safety)
- FCC CFR47 Part 90 (radio)
- FCC CFR47 Part 15 (EMC)

SATEL Proof-TR4+/R4+ TECHNICAL SPECIFICATIONS			
Parameter	RECEIVER (SATEL Proof-TR4+/R4+)	TRANSMITTER (SATEL Proof-TR4+)	Notes
Frequency Range	403 ... 473 MHz		See Note 2 below
Tuning range	70 MHz		
Minimum RF Frequency Step	6.25 kHz @ 12.5 or 25 kHz channel spacing 10 kHz @ 20 kHz channel spacing		
Channel Bandwidth	12.5 kHz / 25 kHz		Programmable
Channel Spacing	12.5, 20 (uses 12.5 kHz channel width), 25 kHz		Programmable
Frequency Stability	<1 kHz		
Maximum Continuous Receiver Input Power without Damage	+3 dBm		
Maximum Receiver Input Power without Transmission Errors	-10 dBm		FEC ON
Sensitivity	-112 dBm @ 25 kHz -114 dBm @ 12.5 kHz		SATEL-4FSK (FEC ON)
	-110 dBm @ 25 kHz -112 dBm @ 12.5 kHz		SATEL-8FSK (FEC ON)
	-101 dBm @ 25 kHz -103 dBm @ 12.5 kHz		SATEL-16FSK (FEC ON)
Blocking	-17 dBm @ 25 kHz -20 dBm @ 12.5 kHz		SATEL-4FSK (FEC ON)
	-18 dBm @ 25 kHz -17 dBm @ 12.5 kHz		SATEL-8FSK (FEC ON)
	-29 dBm @ 25 kHz -25 dBm @ 12.5 kHz		SATEL-16FSK (FEC ON)
Intermodulation Attenuation	75 dB @ 25 kHz 75 dB @ 12.5 kHz		SATEL-4FSK (FEC ON)
	72 dB @ 25 kHz 73 dB @ 12.5 kHz		SATEL-8FSK (FEC ON)
	55 dB @ 25 kHz 60 dB @ 12.5 kHz		SATEL-16FSK (FEC ON)

CO-Channel Rejection	8 dB @ 25 kHz 8 dB @ 12.5 kHz		SATEL-4FSK (FEC ON)
	10 dB @ 25 kHz 11 dB @ 12.5 kHz		SATEL-8FSK (FEC ON)
	21 dB @ 25 kHz 20 dB @ 12.5 kHz		SATEL-16FSK (FEC ON)
Adjacent Channel Selectivity	-33 dBm @ 25 kHz -36 dBm @ 12.5 kHz		SATEL-4FSK (FEC ON)
	-34 dBm @ 25 kHz -34 dBm @ 12.5 kHz		SATEL-8FSK (FEC ON)
	-43 dBm @ 25 kHz -40 dBm @ 12.5 kHz		SATEL-16FSK (FEC ON)
Spurious Rejection	> 67 dB		FEC ON
Transmitter Power		0.01, 0.02, 0.05, 0.1, 0.2, 0.5, 1 W	TX-mode, 50Ω load
Adjacent Channel Power		<-60 dBc	TX-mode, acc. to EN 300 113
Carrier power stability		< ±1.5 dB	
Communication Mode	Half-Duplex		
Data speed of Radio Interface	*4FSK FEC OFF: 19200 bps (25 kHz) / 9600 bps (12.5 kHz) 4FSK FEC ON: 14400 bps (25 kHz) / 7200 bps (12.5 kHz) 8FSK FEC OFF: 28800 bps (25 kHz) / 14400 bps (12.5 kHz) 8FSK FEC ON: 19200 bps (25 kHz) / 9600 bps (12.5 kHz) 16FSK FEC ON: 28800 bps (25 kHz) / 14400 bps (12.5 kHz)		*“SATELLINE-3AS” mode
Air Interface Encryption	AES128 (AES256 optionally) (product variants without encryption available)		Programmable
Modulation	4FSK, 8FSK, 16FSK, GMSK		
Serial Data Interface	RS-232 asynchronous data 4800 – 115200 bps		
Operating Voltage	+7 ... +27.5 Vdc (+15%/-20%)		
Typical Power Consumption	RX 1.3 W (12 V) TX 5.8 W @ 1 W transmitter power (12 V)		
Temperature Ranges	-30 °C ... +65 °C Operational		
	-40 °C ... +75 °C Absolute min / max		
	-25 °C ... +55 °C Complies with standards		
	-40 °C ... +85 °C Storage		
Antenna Connector	50 Ω, TNC female		
Interface Connector	Deutsch DT04-6P-CL09		

Housing	Die cast aluminium enclosure	
Size L x W x H	174 x 95 x 46 mm	
Mechanical standards	IEC60068-2-32, ISO9022-36-08, ISO9022-31-06, ISO9022-33-06	
Weight	<500 g	
IP rating	IP67 / IP69K	See <i>Note 1</i> below
ESD-failure threshold	8 kV contact, 15 kV air discharge	
Immunity	≥10 V/m	
Vibration	≥20 G (20 Hz...2 kHz sinusoidal/random)	

Values are subject to change without a notice.

Note 1: IP67/IP69K rating of the device requires the mating connector to be correctly assembled and connected into the device's Deutsch connector. See details from the connector manufacturer's datasheet.

Note 2: Firmware rejects transmission on 405.925...406.176 MHz frequencies. The frequency band is reserved internationally for emergency transmitters as specified by FCC reference FCC 04-75.

3 SATEL Proof-TR9 TECHNICAL SPECIFICATIONS

SATEL Proof-TR9 complies with the following international standards:

- FCC CFR47 Part 15 (EMC)
- IC RSS-247, ICC RSS-Gen, ICES-003

SATEL Proof-TR9 TECHNICAL SPECIFICATIONS	
Frequency Range	902-928 MHz
Spreading Method	Frequency Hopping
Occupied Bandwidth	230 kHz
Frequency Stability	<1 kHz
Maximum Receiver Input Power without Transmission Errors	-3 dBm
Sensitivity	typ. -109 dBm for BER 10 ⁻⁴
Transmitter Power	0.01, 0.02, 0.05, 0.1, 0.2, 0.5, 1 W
Carrier power stability	< ±1.5 dB
Modulation Method	2-GFSK
Hopping Bands	7, user selectable
Hopping Patterns	15 per band, 105 total, user selectable
Hopping Channels	50-112, user selectable
Frequency Zones	16 Zones, 7 Channels per Zone
Serial Data Interface	RS-232 asynchronous data 4800 – 115200 bps
Operating Voltage	+7 ... +27.5 Vdc (+15%/-20%)
Typical Power Consumption	RX 0.8 W (12 V)
	TX 4.5 W (12 V) @ 1 W transmitter power
Temperature Ranges	-30 °C ... +65 °C Operational
	-40 °C ... +75 °C Absolute min / max
	-25 °C ... +55 °C Complies with standards
	-40 °C ... +85 °C Storage
Antenna Connector	50 Ω, TNC female
Interface Connector	Deutsch DT04-6P-CL09
Housing	Die cast aluminium enclosure
Size L x W x H	174 x 95 x 46 mm
Mechanical Standards	IEC60068-2-32, ISO9022-36-08, ISO9022-31-06, ISO9022-33-06
Weight	<500 g
IP rating	IP67 / IP69K (See Note 1 below)
ESD-failure threshold	8 kV contact, 15 kV air discharge
Immunity	10 V/m
Vibration	≥20 G (20 Hz...2 kHz sinusoidal/random)

Values are subject to change without a notice.

Note 1: IP67 / IP69K rating of the device requires the mating connector to be correctly assembled and connected into the device's Deutsch connector. See details from the connector manufacturer's datasheet.

4 SATEL Proof-TR489 TECHNICAL SPECIFICATIONS

SATEL Proof-TR489 complies with the following international standards:

- EN 300 113 (403-473 MHz frequency band)
- EN 300 220-1, EN 300 220-2 (869.4-869.65 MHz frequency band)
- EN 301 489-1, EN 301 489-5 (EMC)
- IEC 62368-1 (safety)
- FCC CFR47 Part 90 (403-473 MHz frequency band)
- FCC CFR47 Part 15 (EMC)
- IC RSS-247, ICC RSS-Gen, ICES-003

SATEL Proof-TR489 TECHNICAL SPECIFICATIONS on 403-473 MHz			
Parameter	RECEIVER	TRANSMITTER	Notes
Frequency Range	403 ... 473 MHz		See <i>Note 1</i> below
Tuning range	70 MHz		
Minimum RF Frequency Step	6.25 kHz @ 12.5 or 25 kHz channel spacing 10 kHz @ 20 kHz channel spacing		
Channel Bandwidth	12.5 kHz / 25 kHz		Programmable
Channel Spacing	12.5, 20 (uses 12.5 kHz channel width), 25 kHz		Programmable
Frequency Stability	<1 kHz		
Maximum Continuous Receiver Input Power without Damage	+4 dBm		
Maximum Receiver Input Power without Transmission Errors	-9 dBm		FEC ON
Sensitivity	-112 dBm @ 25 kHz -114 dBm @12.5 kHz		SATEL-4FSK (FEC ON)
	-110 dBm @ 25 kHz -112 dBm @12.5 kHz		SATEL-8FSK (FEC ON)
	-101 dBm @ 25 kHz -103 dBm @12.5 kHz		SATEL-16FSK (FEC ON)
Blocking	-17 dBm @ 25 kHz -20 dBm @ 12.5 kHz		SATEL-4FSK (FEC ON)
	-18 dBm @ 25 kHz -17 dBm @ 12.5 kHz		SATEL-8FSK (FEC ON)
	-29 dBm @ 25 kHz -25 dBm @ 12.5 kHz		SATEL-16FSK (FEC ON)
Intermodulation Attenuation	73 dB @ 25 kHz 73 dB @ 12.5 kHz		SATEL-4FSK (FEC ON)
	72 dB @ 25 kHz 73 dB @ 12.5 kHz		SATEL-8FSK (FEC ON)
	55 dB @ 25 kHz 60 dB @ 12.5 kHz		SATEL-16FSK (FEC ON)

CO-Channel Rejection	8 dB @ 25 kHz 11 dB @ 12.5 kHz		SATEL-4FSK (FEC ON)
	10 dB @ 25 kHz 11 dB @ 12.5 kHz		SATEL-8FSK (FEC ON)
	21 dB @ 25 kHz 20 dB @ 12.5 kHz		SATEL-16FSK (FEC ON)
Adjacent Channel Selectivity	-33 dBm @ 25 kHz -36 dBm @ 12.5 kHz		SATEL-4FSK (FEC ON)
	-34 dBm @ 25 kHz -34 dBm @ 12.5 kHz		SATEL-8FSK (FEC ON)
	-43 dBm @ 25 kHz -40 dBm @ 12.5 kHz		SATEL-16FSK (FEC ON)
Spurious Rejection	> 67 dB		FEC ON
Transmitter Power (programmable)		0.01, 0.02, 0.05, 0.1, 0.2, 0.5, 1 W	TX-mode, 50Ω load
Adjacent Channel Power		<-60 dBc	TX-mode, acc. to EN 300 113
Carrier power stability		< ±1.5 dB	
Communication Mode	Half-Duplex		
Data speed of Radio Interface	*4FSK FEC OFF: 19200 bps (25 kHz) / 9600 bps (12.5 kHz) 4FSK FEC ON: 14400 bps (25 kHz) / 7200 bps (12.5 kHz) 8FSK FEC OFF: 28800 bps (25 kHz) / 14400 bps (12.5 kHz) 8FSK FEC ON: 19200 bps (25 kHz) / 9600 bps (12.5 kHz) 16FSK FEC ON: 28800 bps (25 kHz) / 14400 bps (12.5 kHz)		**“SATELLINE-3AS” mode
Air Interface Encryption	AES128 (AES256 optionally) (product variants without encryption available)		Programmable
Modulation	4FSK, 8FSK, 16FSK, GMSK		
Typical Power Consumption	RX 1.3 W (12 V) TX 7.0 W @ 1 W transmitter power (12 V)		

Values are subject to change without a notice.

Note 1: Firmware rejects transmission on 405.925...406.176 MHz frequencies. The frequency band is reserved internationally for emergency transmitters as specified by FCC reference FCC 04-75.

SATEL Proof-TR489 TECHNICAL SPECIFICATIONS on 869.4-869.65 MHz			
Parameter	RECEIVER	TRANSMITTER	Notes
Frequency Range	869.4 ... 869.65 MHz		as defined by CEPT/ERC/REC 70-03 See <i>Note 1</i>
Tuning range	0.25 MHz		
Minimum RF Frequency Step	6.25 kHz		
Channel Spacing / Width	25, 50 kHz		Programmable. 50 kHz, see <i>Note 2</i>
Frequency Stability	<1 kHz		
Maximum Continuous Receiver Input Power without Damage	+15 dBm		
Maximum Receiver Input Power without Transmission Errors	-9 dBm		FEC ON
Sensitivity	-108 dBm @ 25 kHz		SATEL-4FSK (FEC ON)
Blocking	>82 dB @ 1 MHz offset >83 dB @ 2 MHz offset >85 dB @ 5 MHz offset		SATEL-4FSK (FEC ON)
Intermodulation Attenuation	> 57 dB @ 25 kHz		FEC ON
CO-Channel Rejection	> -17 dB @ 25 kHz		FEC ON
Adjacent Channel Selectivity	>60 dB @ 25 kHz		SATEL-4FSK (FEC ON)
Spurious Rejection	> 70 dB		FEC ON
Transmitter Power (programmable)	0.01, 0.02, 0.05, 0.1, 0.2, 0.5 W		TX-mode, 50Ω load
Adjacent Channel Power	acc. to EN 300 220		TX-mode
Transient Adjacent Channel Power	acc. to EN 300 220		TX-mode
Carrier power stability	< ±1.5 dB		
Communication Mode	Half-Duplex		
Data speed of Radio Interface	4FSK FEC OFF / ON: 19200 / 14400 bps (25 kHz) 38400 / 28800 bps (50 kHz)		
Air Interface Encryption	AES128 (AES256 optionally) (product variants without encryption available)		Programmable
Modulation	4FSK		
Typical Power Consumption	RX 1.4 W (12 V) TX 6.5 W (12 V) @ 0.5 W transmitter power		

Values are subject to change without a notice.

Note 1 Nominal operating frequency: 25 kHz channel width @ 869.4125...869.6375 MHz / 50 kHz channel width @ 869.4250...869.6250 MHz.

Note 2 50 kHz channel bandwidth support at 800 MHz band is available in the devices that are manufactured after 2024 week 27 (1st of July 2024) with firmware version 07.xx.2.5.1.53 or newer. Devices that are manufactured before the mentioned date or with the firmware version preceding 07.xx.2.5.1.53 can't be updated to support 50 kHz channel bandwidth in the field. This task can be done only at the SATEL factory. Please contact SATEL for the details. Manufacturing date can be verified from the device serial number, where the first two digits are the manufacturing year and the next two digits being the manufacturing week (serial number starting with 2427 is manufactured in 2024, week 27).

SATEL Proof-TR489 TECHNICAL SPECIFICATIONS on 902-928 MHz	
Frequency Range	902-928 MHz
Spreading Method	Frequency Hopping
Occupied Bandwidth	230 kHz
Frequency Stability	<1 kHz
Maximum Receiver Input Power without Transmission Errors	-3 dBm
Sensitivity	typ. -109 dBm for BER 10 ⁻⁴
Transmitter Power	0.01, 0.02, 0.05, 0.1, 0.2, 0.5, 1 W
Carrier power stability	< ±1.5 dB
Modulation Method	2-GFSK
Hopping Bands	7, user selectable
Hopping Patterns	15 per band, 105 total, user selectable
Hopping Channels	50-112, user selectable
Frequency Zones	16 Zones, 7 Channels per Zone
Typical Power Consumption	RX 0.8 W (12 V) TX 4.5 W (12 V) @ 1 W transmitter power

Values are subject to change without a notice.

SATEL Proof-TR489 TECHNICAL SPECIFICATIONS (characteristics common to all frequency bands)	
Parameter	
Serial Data Interface	RS-232 asynchronous data 4800 – 115200 bps
Operating Voltage	+7 ... +27.5 Vdc (+15%/-20%)
Temperature Ranges	-30 °C ... +65 °C Operational
	-40 °C ... +75 °C Absolute min / max
	-25 °C ... +55 °C Complies with standards
	-40 °C ... +85 °C Storage
Antenna Connector	50 Ω, TNC female
Interface Connector	Deutsch DT04-6P-CL09
Housing	Die cast aluminium enclosure
Size L x W x H	174 x 95 x 46 mm
Mechanical standards	IEC60068-2-32, ISO9022-36-08, ISO9022-31-06, ISO9022-33-06
Weight	<500 g
IP rating	IP67 / IP69K (See <i>Note 1</i> below)
ESD-failure threshold	8 kV contact, 15 kV air discharge
Immunity	>10 V/m
Vibration	>20 G (20 Hz...2 kHz sinusoidal/random)

Values are subject to change without a notice.

Note 1: IP67 / IP69K rating of the device requires the mating connector to be correctly assembled and connected into the device's Deutsch connector. See details from the connector manufacturer's datasheet.

5 CONFIGURATION

The configuration of settings can be changed easily - the next chapters describe the details:

SATEL SW tools

Easy-to-use SATEL software tools suit most cases. Please see additional information in next chapters.

SL commands

A terminal device can command or configure the radio modem by using special commands. SL commands are applied especially in cases where radio modems are to be integrated seamlessly inside a system behind the integrator's own user interface.

5.1 SATEL NETCO DEVICE software

SATEL NETCO DEVICE is a software for configuring and reprogramming a SATEL device. The configuration parameters can be read and written from/to the locally connected, powered device. The device configuration can be also created/saved/explored from/to a file without device connection.

The most common use case for which the SATEL NETCO DEVICE is optimized for is editing existing parameters in a SATEL radio product using local connection, such as serial interface.

Please see additional information from SATEL WEB pages at:

<https://www.satel.com/products/software/>

The software is available from SATEL WEB pages at: <https://www.satel.com/support-and-services/downloads/>

5.2 Configuration Manager software

SATEL Configuration Manager is a software for configuring and reprogramming a SATEL device. The parameters can be read and written from/to the connected, powered device. The program file can be saved into a separate file to be used to other devices.

The most common use case for which the SATEL Configuration Manager is optimized for is editing existing parameters in a SATEL radio product using locally connected product over a serial interface. Minimum requirements: COM port with baud rate min. 9600 bps (alternatively with industrial level USB-RS-232 converter).

Please see additional information from SATEL WEB pages at:

<https://www.satel.com/products/software/>

The software is available from SATEL WEB pages at: <https://www.satel.com/support-and-services/downloads/>

QuickStart

Preliminary settings:

1. Save the SATEL Configuration Manager files in the same directory.
2. Connect the modem to the PC using a proper interface cable.
3. Connect power to the modem. Before connecting, check that you have correct supply voltage.
4. Open the SATEL Configuration Manager program. Check from the “Program Preferences” tab, that you have selected correct COM-port number and that the serial port settings match to the modem. Default settings are 115200 bps, 8 bit, none parity, 1 stop bit.
5. To establish connection between the modem and the PC, click the blue Connect tab. To get the radio modem info, click blue Read Settings tab.
6. Check the settings and modify if needed.
7. Store settings to a modem using “Write settings” –button.
8. More information about Configuration Manager can be found from user guide.

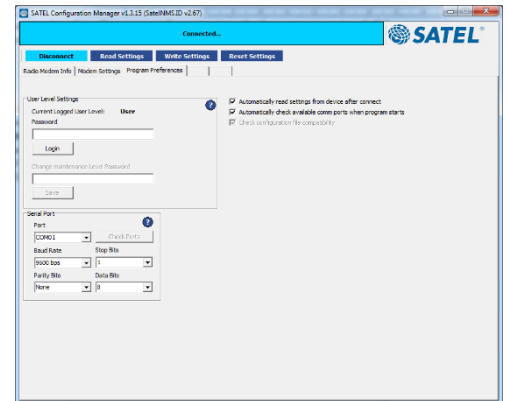

5.3 Changing parameters using SL commands

The controlling terminal device can change the configuration settings of the module. This is accomplished with the help of SL commands. SL commands can be used to change e.g. the frequency or addresses. It is also possible to ask the radio transceiver module to show current settings which are in use.

5.3.1 SL Commands

The controlling terminal device can change the configuration settings of a radio. This is accomplished with the help of SL commands, which can be used during data transfer. SL commands can be used to change e.g. the frequency or addresses. It is also possible to interrogate a radio modem to gain information concerning current settings that are in use. SL command -setting must be enabled before they can be used.

An SL command is a continuous string of characters, which is separated from other data by pauses which are equal or greater than time defined by Pause length parameter (default=3 characters) in the set-up. No extra characters are allowed at the end of an SL command. Serial interface settings are the same as in data transfer. SL command is properly recognised also in the case when the command string is terminated by <CR> (=ASCII character no. 13, Carriage Return, 0x0d) or <CR><LF> (<LF> = ASCII char. no. 10, Line Feed, 0x0a). Pause according to set Pause Length -parameter is required also in this case. If multiple SL commands are sent to the module, the next command can be given after receiving the response ("Ok" or "Error") of the proceeding command. In addition, it is recommended to implement a timeout to the terminal software for recovering the case when no response is received from the radio module.

The transceiver module will acknowledge all commands by returning an "**OK**" (command carried out or accepted) or the requested value, or an "**ERROR**" (command not carried out or interpreted as erroneous) message. SL command response time depends on the used command. Typical response time is ~100ms and upwards. Recommended safe timeout for SL command response is 500ms.

CR/LF characters are added to end the response messages (unless they are already present) to make parsing easier. Settings can be toggled, SL Commands ON/OFF, CR/LF ON/OFF.

To get information of the latest and/or special SL commands please contact SATEL or local SATEL distributor: <https://www.satel.com/where-to-buy/>.

5.3.2 Command Mode

When the SL commands are enabled, there are possibilities that the user data may start with the characters "SL" which is handled as the SL command. This has caused the firmware to go to the continuous SL command search mode and any data has not been sent or even an "**ERROR**" acknowledgment has been received. To avoid this kind of behaviour the user can disable the SL commands.

The SL commands can be disabled or enabled by using SL commands or toggling the "*SL Command mode*" parameter via SATEL SW tools, SATEL NETCO DEVICE or SATEL Configuration Manager (maintenance access level required).

By default, the *SL Command mode* is set to **ON**. If the *SL Command mode* is set to **OFF**, then the SL commands can be enabled or disabled by using the below described procedure. Regardless of the original SL command –setting state, changing the setting state with this procedure will affect the reception process of the radio module.

Radio can be set to *Command Mode* separately with “+++” command, regardless of the set SL command mode (ON/OFF). *Command mode* enables forcibly the SL command mode and disables the radio interface functions (Tx/Rx). By exiting from the Command Mode, user defined SL command parameter mode is restored, as well as radio interface functions.

To enable the *Command mode*:

- Send three “+” characters via serial port so that there is at least three bytes delay (according to Pause Length -setting) between each character. The response is “**OK**”, when successfully set.
<+><at least three bytes pause*><+><at least three bytes pause*><+>

To disable the *Command mode*:

- Send three “-” characters via serial port so that there is at least three bytes delay (according to Pause Length -setting) between each character. The response is “**OK**”, when successfully set.
<-><at least three bytes pause*><-><at least three bytes pause*><->

*Pause Length -setting

Note! The “+ + +” and “- - -” procedures are not recommended to be used when radio is transmitting or receiving data (i.e., the application data occupies the TD or RD lines of the radio).

5.3.3 Syntax of SL commands

An SL command is a one continuous string of specific characters, which is separated from other data by pauses that are equal or greater than the time defined by *Pause Length* setting (default value is 3 characters). The continuous here means that there are no pauses between the adjacent characters inside the SL command on the serial line.

The syntax of an SL command is: **SL<Command><CR><LF>**, where:

<Command> is the actual character string defining the actual command.

<CR> is Carriage Return (ASCII character 13, 0x0d in hexadecimal)

<LF> is LineFeed (ASCII character 10, 0x0a in hexadecimal).

Note that the use of <CR> <LF> is optional but recommended.

The radio modem will acknowledge all commands by returning "OK" (command carried out or accepted) or the requested value, or "ERROR" (command not carried out or interpreted as erroneous) message.

If multiple SL commands are sent to the radio modem, the next command can be given after receiving the response ("OK" or "ERROR") of the proceeding command. In addition, it is recommended to implement a timeout to the terminal software for recovering the case when no response is received from the radio modem.

6 SERIAL INTERFACE

The radio modem is referred to as DCE (Data Communication Equipment) whereas the device connected to it, typically a PLC or a PC, is referred to as DTE (Data Terminal Equipment).

To transfer data, the physical interface between DCE and DTE must be compatible and properly configured. This chapter describes shortly the basics of the physical interface options, the related settings and the operation of the serial interface.

Before connecting DTE (Data Terminal Equipment) to the radio modem, make sure that the configuration matches the physical interface (electrical characteristics, timing, direction and interpretation of signals).

6.1 Pause length

The modem recognises a pause on the serial line (a pause is defined as a time with no status changes on the UART interface TD-line). The pause detection is used as criteria for:

End of radio transmission - When the transmit buffer is empty and a pause is detected, the modem stops the transmission and will then change the radio to the receive mode.

SL command recognition - For a SL command to be valid, a pause must be detected before the actual command character string.

User address recognition - For the start character to be detected, a pause must precede it in transmission.

Traditionally, in asynchronous data communication, pauses have been used to separate serial messages from each other. However, the use of non-real-time operating systems (frequently used on PC-type hardware) often adds random pauses, which may result in the user data splitting into two or more separate radio transmissions. This may cause problems especially in the systems including repeater stations.

To match the operation of the radio modem to the user data, the Pause length parameter can be adjusted on the programming menu. It may have any value between 3 and 255 characters. The default value is 3 characters.

Notes:

The absolute time of Pause length is depending on the serial port settings. For example, 1 character is ~1.04 ms at 9600 bps / 8N1 (10 bits).

The maximum absolute time is always 170 ms independent from the value of the Pause length given in the set-up.

An increase in the Pause length increases the round-trip delay of the radio link correspondingly; this is because the radio channel is occupied for the time of the Pause length after each transmission (the time it takes to detect a pause). If this is not acceptable, the TX delay setting may also be useful in special cases.

6.2 Data buffering

Whenever the radio modem is in *Data Transfer Mode* it monitors both the radio channel and the serial interface. When the terminal device starts data transmission the radio modem switches to transmission mode. At the beginning of each transmission a synchronisation signal is transmitted, and this signal is detected by another radio modem, which then switches into receive mode. During the transmission of the synchronisation signal the radio modem buffers data into its memory. Transmission ends when a pause is detected in the data sent by the terminal device, and after all buffered data has been transmitted. When the serial interface speed is the same or slower than the speed of the radio interface, the internal transmit buffer memory cannot overflow. However, when the serial interface speed exceeds the speed of the radio interface, data will eventually fill transmit buffer memory. In this instance, it will take a moment after the terminal device has stopped transmission of data for the radio modem to empty the buffer and before the transmitter switches off. The maximum size of transmit buffer memory is one kilobyte (1 kB). If the terminal device does not follow the status of the CTS-line and transmits too much data to the radio modem, the buffer will be emptied, and the transmission is restarted.

In the receive mode, the buffer works principally in the above-described way thus evening out differences in data transfer speeds. If the terminal device transmits data to a radio modem in receive mode, the data will go into transmit buffer memory. Transmission will start immediately when the radio channel is available.

7 MODEM SETTINGS

The radio modem is delivered with the default configuration below unless otherwise ordered.

RADIO SETTINGS (these settings apply to 403-473 MHz frequency band)		
Setting	Default value	Range of values
TX frequency	438.000 MHz	403-473 MHz
RX frequency	438.000 MHz	403-473 MHz
Reference Frequency	438.000 MHz	403-473 MHz
Channel Spacing/Width	12.5 kHz	12.5 kHz / 12.5 kHz 20 kHz / 12.5 kHz 25 kHz / 25 kHz
Min. RF Frequency Step	-	6.25 kHz @ 12.5 kHz channel spacing 10 kHz @ 20 kHz channel spacing 6.25 kHz @ 25 kHz channel spacing
TX Power	1000 mW	Range: 10, 20, 50, 100, 200, 500 or 1000 mW
Signal threshold	-118 dBm	- 80 ... -118 dBm
TX Delay	0 ms	0-65535 ms
Radio Compatibility <i>(Available set depends on the factory configuration)</i>	SATELLINE-3AS	SATELLINE-3AS PacCrest-4FSK PacCrest-GMSK PacCrest-FST TrimTalk450s(P) TrimTalk450s(T) SATELLINE-2ASxE SOUTH SATEL-8FSK-1 (FEC OFF) SATEL-8FSK-2 (FEC ON) SATEL-16FSK-1 (FEC ON) RTCM SC135 1 25 kHz FEC ON RTCM SC135 2 12.5 kHz FEC ON RTCM SC135 3 25 kHz FEC OFF RTCM SC135 4 12.5 kHz FEC OFF
RX Address Enabled	OFF	ON/OFF
TX Address Enabled	OFF	ON/OFF
FEC Mode	OFF	ON/OFF (applies only to SATELLINE-3AS radio compatibility mode)
Error check	OFF	OFF, CRC8Partial, CRC8Full, CRC16Full
Repeater Mode	OFF	ON/OFF
TX Delay	0	0 65535 ms
Over-the-Air-Encryption	OFF	ON/OFF
Use Channel List	OFF	ON/OFF
Add RSSI to Data	OFF	ON/OFF
Radio State	TX	TX/RX
Priority	TX	TX/RX

RADIO SETTINGS (these settings apply to 869.4-869.65 MHz frequency band)		
Setting	Default value	Range of values
TX frequency	869.41250 MHz	869.41250 - 869.63750 MHz
RX frequency	869.41250 MHz	869.41250 - 869.63750 MHz
Reference Frequency	869.000 MHz	
Channel Spacing/Width	25 kHz	25 kHz / 25 kHz 50 kHz / 50 kHz
Min. RF Frequency Step	-	25 kHz
TX Power	500 mW	Range: 10, 20, 50, 100, 200 or 500 mW
Signal threshold	-118 dBm	- 80 ... -118 dBm
TX Delay	0 ms	0-65535 ms
Radio Compatibility	SATELLINE-3AS	SATELLINE-3AS
RX Address Enabled	OFF	ON/OFF
TX Address Enabled	OFF	ON/OFF
FEC Mode	OFF	ON/OFF
Error check	OFF	OFF, CRC8Partial, CRC8Full, CRC16Full
Repeater Mode	OFF	ON/OFF
TX Delay	0	0 65535 ms
Over-the-Air-Encryption	OFF	ON/OFF
Use Channel List	OFF	ON/OFF
Add RSSI to Data	OFF	ON/OFF
Radio State	TX	TX/RX
Priority	TX	TX/RX

RADIO SETTINGS (these settings apply to 902-928 MHz frequency band)		
Operation Mode		
<i>Setting</i>	<i>Default value</i>	<i>Range of values</i>
Modem mode	Point-to-Multipoint Slave	Point-to-Point Slave Point-to-Multipoint Master Point-to-Multipoint Slave Point-to-Point Slave/Repeater Point-to-Point Repeater Point-to-Multipoint Repeater Point-to-Multipoint Slave (RX Only)
Transmission Characteristics		
<i>Setting</i>	<i>Default value</i>	<i>Range of values</i>
Frequency Key	5	0...9 / A...E
Frequency Zones	All Enabled	16 selectable zones
Hop Table Version	0 (=902 - 928 MHz)	0 (=902 - 928 MHz) 1 (=915 - 928 MHz) 2 (=902 - 928 MHz, 16 fewer frequencies than full U.S. set, actual frequencies 903.744-926.3232 MHz) 3 (=916 - 920 MHz) 4 (=921 - 928 MHz) 5 (=902 - 911 & 919 - 928 MHz (911-919 MHz blocked)) 6 (=902 - 915 MHz)
Hop Table Size	112	50...112
Max Packet Size	8	0...9
Min Packet Size	9	0...9
Transmit rate	Normal	Normal
RF Data Rate	Normal	Normal
Slave Security	ON	OFF / ON
Transmit Power	1000 mW	10, 20, 50, 100, 200, 500 or 1000 mW
RTS to CTS	Disabled	Disabled
Retry Timeout	255	8...255
Multipoint Parameters		
<i>Setting</i>	<i>Default value</i>	<i>Range of values</i>
Repeaters	Enabled	Enabled / Disabled
Master Packet Repeat	2	0...9
Max Slave Retry	9	0...9
Retry Odds	9	0...9
Repeater Frequency	Disabled	Enabled / Disabled
Network ID	255	0...4095
Slave/Repeater	Disabled	Enabled / Disabled
RX Subnet	Disabled	Roaming / Subnet Id [1...9, A...E] / Disabled
TX Subnet	Disabled	Roaming / Subnet Id [1...9, A...E] / Disabled

SERIAL PORT RELATED SETTINGS		
<i>Setting</i>	<i>Default value</i>	<i>Range</i>
Data speed	115200 bps	4800 – 115200 bps
Data bits	8	8
Parity bits	None	None, Even, Odd
Stop bits	1	1
Pause length	3 bytes	3....255
SL-commands	ON	ON/OFF
Power Save Mode	OFF	ON/OFF

8 CONNECTORS

8.1 Antenna connector

All models have a single TNC female type antenna connector with impedance of 50 Ohm. The antenna should always be connected when the power is on.

8.2 Power/Data connector

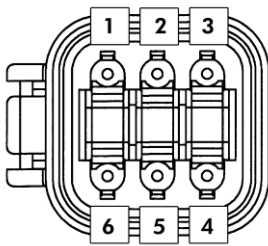

Pin-out of **Deutsch DT04-6P-CL09** power/data connector

Pin	Signal	Type and Direction	Description
1	PWR	Power input	Operating voltage +7...+27.5 VDC
2	-	-	not connected (reserved for future needs)
3	-	-	not connected (reserved for future needs)
4	TD	RS-232 input	Transmit Data serial data from terminal equipment to modem (Port 1)
5	RD	RS-232 output	Receive Data serial data from modem (Port 1) to terminal equipment
6	GND	Ground	Signal and chassis ground

NOTES:

- The power supply must provide current limiting (**FUSE 1.5A maximum size**) against short circuits
- IP67/IP69K rating of the device requires the mating connector to be correctly assembled and connected into the device's Deutsch connector. See details from the connector manufacturer's datasheet.
- GND (pins 6), the metal enclosure and the outer contact of the antenna connector are galvanically connected
- Follow the guidelines for safe installation of the equipment - see the chapters "INSTALLATION" and "GROUNDING"

9 RF INTERFACE

NOTE! This chapter refers to products using 403-473 MHz frequency band, please contact SATEL for more details concerning 900 MHz frequency band.

All SATEL Proof radio modems have a female TNC antenna connector (50 Ohm impedance).

SATEL Proof-TR4+/R4+/TR489 (403 – 473 MHz) offer the radio settings for user to select:

- Channel spacing: 25 kHz, 20 kHz or 12.5 kHz
- Frequency can be any 6250 Hz divisible frequency between 403...473 MHz in case the Channel Spacing is 25 kHz or 12.5 kHz (for example 403.000 MHz, 403.006250 MHz, 403.012500 MHz), 10 kHz if the channel spacing is 20 kHz (uses 12.5 kHz channel width).

The data speed of the radio interface depends on the radio channel spacing and selected radio modulation level. See technical specification for details.

The data speed over-the-air is irrespective of the data speed of the serial interface. If the two differ from each other, the radio modem will buffer the data (max 1 kB) temporarily.

Please note that any communication link introduces an extra time delay called latency that affects the system performance. It is the minimum time experienced by the data between the moment when the data appears at the serial interface of the transmitting modem and the receiving modem.

9.1 Transmitter

The output power of the transmitter is adjustable (see the table below for available values). The greatest allowable power depends on limits set by local authorities, which should not be exceeded under any circumstances. The output power of the transmitter should be set to the smallest possible level such that it still ensures error free connection under variable conditions. Excessively high output power levels used in short link spans can cause interferences and affect to the overall operation of the system.

Transmitter output power levels	
Output power (mW)	Output power (dBm)
10mW	+10 dBm
20mW	~+13 dBm
50mW	~+17 dBm
100 mW	+20 dBm
200 mW	+23 dBm
500 mW	+27 dBm
1000 mW	+30 dBm

The antenna (or a 50 Ohm attenuator) should be always connected to the antenna connector while the transmitter is being used in order to guarantee the maximum lifetime of the transmitter.

NOTE!

Setting the transmitter output power to such a level that exceeds the regulations set forth by local authorities is strictly forbidden. The setting and/or using of non-approved power levels may lead to prosecution. SATEL and its distributors are not responsible for any illegal use of its radio equipment, and are not responsible in any way of any claims or penalties arising from the operation of its radio equipment in ways contradictory to local regulations and/or requirements and/or laws.

9.2 Receiver

The sensitivity of the receiver depends on the channel spacing of the radio modem (=data speed of the radio interface), selected frequency band and on the mode of the FEC (error correction). See technical specification for details.

The radio modem measures the received signal strength (RSSI) of the receiver constantly. The Signal Threshold setting determines the received signal level above which the search for the radio messages is active. If the threshold is set too low, it is possible that the receiver is trying to synchronise itself with noise. In such a case the actual data transmission might remain unnoticed. If the threshold is set too high, the weak data transmissions will be rejected although they could be otherwise receivable. Signal threshold should only be changed for a reason – for example in the following cases:

Continuous interference is present, and the desired signal is strong. In this case the signal threshold can be increased to prevent the modem from synchronising to the interfering signal(s) and /or possible noise.

Maximum sensitivity should be achieved, and the desired signal is very weak. In this case the sensitivity could increase by decreasing Signal threshold. This type of situation is usually a sign of a poorly constructed radio network / contact. Bit errors and momentary loss of signals can be expected in this kind of a situation. Some data might be successfully transferred.

The RSSI can be requested also locally by using a special SL command (SL@R?). The RSSI value is available 7s after the receiving the message.

Signal Threshold value range: -80 ... -118 dBm

Default value: -118 dBm

Note that the feature is OFF in case the value is -118 dBm.

9.3 Encryption

Data security is often a concern in radio communication. SATEL-Proof-TR4+/R4+/TR489 with AES128-bit encryption (CTR-mode) ensure privacy in the radio network. The principle of encryption in the radio path is to collect a certain amount of data to a shift register and manipulate it according to a certain rule. Every data packet is encrypted individually. The process of encryption adds 10 ms delay in the data flow to each sent data packet (<5 characters) and must be avoided in the cases where low latency is the most important requirement.

AES is open-source software from public domain. Author: Brian Gladman (U.K). The CTR-mode is SATEL's in-house implementation.

The SATEL Proof-TR4+/R4+/TR489 models that support encryption can be viewed in SATEL WEB sites at www.satel.com/products/. The radio models that do not support encryption are compatible with the radio models with the encryption when the encryption feature is disabled. It is not possible to update/change the models NOT supporting the encryption to support this feature in the field. This task can be executed is SATEL factory premises and will be charged according to the service price list. The factory default value for the encryption feature is OFF state.

The encryption password key is generated by using Main and Aux –keys + in the beginning of the data packet transferred changing 32-bit string. It is mandatory to insert both information keys with the mentioned length keys. Options for generating the encryption keys are:

- Manually via terminal connection:
 - o SL commands
- Automatically with password via SATEL NETCO DEVICE or SATEL Configuration Manager software (generates automatically the Main and Aux keys)

The equivalency of the encryption keys between radio modems can be verified from the Key Hash –information field. Last 4 marks indicates the equivalency [0-9, A-F].

NOTE! This feature is designed for SATELLINE-3AS, SATEL-8FSK-1, SATEL-8FSK-2 and SATEL-16FSK-1 –radio compatibility modes.

9.4 Radio state

This setting allows users to disable/enable the transmitter. Unless overridden by the factory configuration, users can select state of the radio by using SATEL NETCO DEVICE or SATEL Configuration Manager software and selecting the value Enabled Radio States:

- Tx/Rx (both transmitter and receiver are enabled)
- Rx Only (transmitter out of use, receiver enabled)

In case the factory configuration defines the modem as Rx-only device, the value can't be changed by the users.

NOTE! Rx Only device replies "0mW" to SL@P? (Get transmitter power) command.

9.5 Priority RX/TX

Priority setting selects the priority between reception and transmission. The setting can be changed in Programming Mode. By default, transmission has higher priority than reception i.e. the default value is Priority TX.

Priority TX means that a terminal device attached to a radio modem decides the timing of the transmission. The transmitter is immediately switched on when the terminal device starts to output data. Should reception be in progress, the radio modem will stop it and change to a transmit state. There is no need to use any handshaking for the control of timing.

Priority RX means, that a radio modem tries to receive all data currently in the air. If a terminal device outputs data to be transmitted (or an SL command) it will be buffered. The radio modem will wait until the reception has stopped before transmitting the buffered data. This will result in timing slacks to the system but decreases the number of collisions on the air; this is particularly useful in systems based on multiple random accesses.

9.6 Forward Error Correction (FEC)

FEC improves the reliability of data transfer over the radio by adding additional correction information to the radio messages. Based on that information, the receiving radio modem will be able to correct erroneous bits provided the ratio of erroneous and correct bits is reasonable. However, the use of FEC decreases the data throughput, because the amount of transmitted data increases about 30 % (see Appendix A). FEC should be used on long distance links and/or if the radio channel is “noisy” in other words suffering from interfering signals.

NOTE! All radio modems, which are to communicate with each other, must have the same setting for FEC (ON or OFF). If the transmitting radio modem and the receiving radio modem has different settings, data will not be received.

9.7 Error checking

When the error checking is switched on, the radio will add a checksum to the transmitted data. When the data is received, the checksum is verified before data is forwarded to the serial port. Options for error checking can be accessed either via SL commands or SW tools (SATEL NETCO DEVICE or SATEL Configuration Manager). Error Check modes:

OFF (default setting). Received data is not verified at all. In practice, this is the fastest way to operate, because the data is given out from serial port immediately after it has been received. This is recommended method if the application protocol already includes error checking functions.

CRC8 Partial verifies the data in small blocks, and they are delivered to DTE as sub messages after validating. Once an error is detected, the rest of the message is ignored. In practice, if the error appears in the middle of the message, the first part is forwarded to DTE and the data in erroneous sub-message and after that will be lost.

CRC-16 Full and CRC-8 Full check adds checksum characters accordingly at the end of the user data message. At the reception end the receiver receives first the whole package and if the checksum matches the data message is forwarded to the serial port.

! CRC-8 Partial and CRC-8 Full check activate an internal control on the radio link. These checksum types can't be viewed in the serial line data flow. CRC-16 Full check adds the checksum to data. It is possible include the checksum into the received data in the serial line by setting the CRC-16 Full check to OFF state at the receiving radio(s).

In typical use case, if checksum is preferred in the system, it is recommended to use the CRC-16 Full check -mode and set the parameter equally to the radios in the same radio network. Additional data transfer delay will be added approximately according to the data packet size to the total transfer delay.

NOTE! This feature is designed for SATELLINE-3AS, SATEL-8FSK-1, SATEL-8FSK-2 and SATEL-16FSK-1 –radio compatibility modes.

9.8 TX delay

The transceiver can be configured to delay the beginning of a radio transmission by 1...65000 ms. The function can be used to prevent packet contention in a system, where all substations would otherwise answer a poll of a base-station simultaneously. During this delay data sent to the radio modem is buffered. Even when the priority setting is "RX", the radio modem is prevented to change over to the receiving mode during the period of the TX delay. If TX delay is not needed, its value should be set to 0 ms.

9.9 Add RSSI to data

RSSI info "\02RSSI:-nnn dBm\03\0D\0A" will be concatenated to the end of serial port messages, nnn is three digit decimal number.

9.10 Separate RX/TX-frequencies

Modem can transmit (TX-frequency) and receive (RX-frequency) on separate frequencies. The switch between the frequencies introduces an extra 40 ms delay in the data transfer that must be taken account when designing the system.

9.11 Call Sign

Call sign means that the modem transmits its Call sign ID periodically using Morse keying.

Call sign is configured using three settings:

- a) Call sign mode sets Call sign operation ON/OFF.
- b) Call sign ID defines Morse code to be transmitted, max. sixteen characters, capital letters and numbers are allowed (lower case letters are converted automatically to uppercase letters).

If Call sign mode is not used (OFF) you can enter e.g. "CALLSIGN" for the Call sign ID.

- c) Call sign timer is the interval (1...30 min) between Call sign transmissions.

One Call sign transmission may take several seconds to transmit, depending on the Call sign ID.

Default value: Call sign mode OFF

9.12 Channel list

Available for 400MHz frequency band. A list of predefined radio channels can be stored in the memory in order to change the radio settings simply by switching between the channels. Each channel carries the following info:

- Channel number (any number -32767...32767)
- Transmitter/Receiver frequency
- Channel width (12.5, 20 or 25 kHz)
- Transmitter power level (optional)

Additionally, the default channel that the radio modem uses after a reset is defined.

When TX frequency of the active channel is set to 0, the radio modem operates as receive-only device (in case the value of Rx frequency is valid).

Channel lists can be created and utilized by using either SATEL NETCO DEVICE or SATEL Configuration Manager software tools or SL commands. Software tools provide a channel list editor (snapshots below) for creating and saving a channel list in the radio modem, or in a file for later usage.

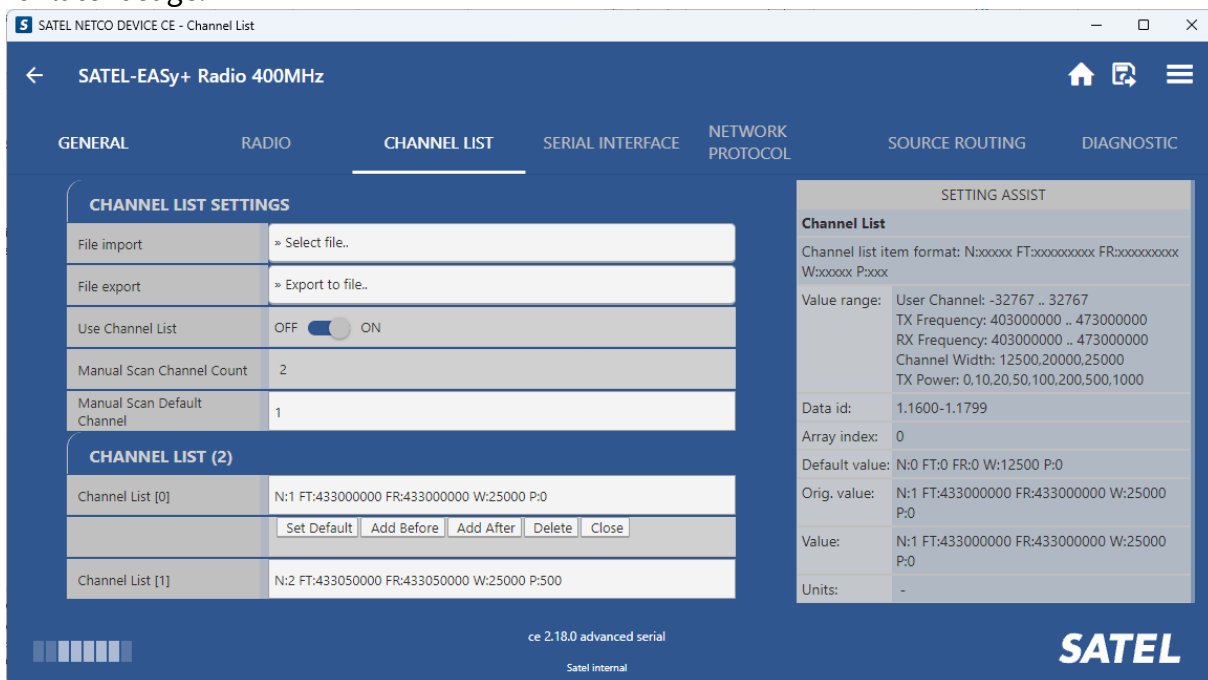

SATEL NETCO DEVICE.

The screenshot shows a window titled "Channel Selector" with a "Default Channel Set" header. Below the header is a toolbar with buttons: Clear, Load, Save, Add, Edit, Up, Down, Set default, Delete, and Close. The main area contains a table with the following data:

Index	User Channel	TX Frequency	RX Frequency	Channel Width	Tx Power
0	0	430000000	430000000	12500	1000
1	1	431000000	431000000	12500	1000
2	2	432000000	432000000	12500	1000

SATEL Configuration Manager.

Entering the Channel List -feature parameters require elevated access level to software tools.

SL commands provide an interface for a host device to command the radio modem directly. An example of the procedure for creating or replacing a channel list:

1. Clear existing channel list (SL\$C=0)
2. Set channel info for each of the channels to be created starting from index 0 (SL\$L=)
3. Set number of channels in channel list (SL\$C=)
4. Set the default channel (SL\$D=)
5. Verify the new configuration:
 - Get number of channels in channel list (SL\$C?)
 - Get channel info for each of the channels (SL\$L?)
 - Get the default channel (SL\$C?)
7. Enable Channel list (SL\$M=1) in order to activate the Channel list
8. Save the settings (SL>**>)

9.13 Repeater mode

Repeaters and addressing may be used to extend the coverage area of a radio modem network, and to direct messages to selected radio modems in the network. In large systems, with several repeaters and formed repeater chains, it is often practical to use routing instead of plain addresses.

In circumstances where it is necessary to extend the coverage area of a radio modem network, modem can be used as repeater stations.

The maximum size of a repeated data packet is 1kB (kilobyte). The Repeater Function is switched on in the radio settings. In the repeater mode the radio modem will function as a totally independent unit. Other devices are not necessary.

A radio modem acting as a repeater can also be used to receive and transmit data. In repeater mode the radio modem will transmit the received data to the serial interface in a normal fashion. The difference being that the received data will be buffered into the buffer memory. After reception the radio modem will re-transmit the buffered data using the same radio channel as in reception. Data received through the serial interface a radio modem in repeater mode will transmit normally.

The same network may include several repeaters, which operate under the same base station. Repeaters may also be chained; in which case a message is transmitted through several repeaters. In systems with more than one serially or parallelly chained repeater, addressing or routing protocol must be used to prevent a message ending up in a loop formed by repeaters, and to ensure that the message finally reaches only the intended radio modem.

Please contact SATEL for more information of Repeater- and Addressing –features.

9.14 Radio compatibility

SATEL provides several radio compatibility modes:

- for selecting the optimum radio solution that fits the application
- for enabling the interoperability between devices made by different manufacturers

SATEL-Proof radio modems support the original SATEL radio compatibility modes:

- SATELLINE-3AS (4FSK, FEC ON/OFF is selected by the separate FEC setting) (option 0)
- SATEL-8FSK-1 (8FSK/FEC OFF) (option 20)
- SATEL-8FSK-2 (8FSK/FEC ON) (option 21)
- SATEL-16FSK-1 (16FSK/FEC ON) (option 22)

Additional to the native SATEL radio compatibility modes, also the following radio compatibility modes are supported by the 403 - 473 MHz frequency band product variants.

- Pacific Crest compatible modes:
 - PacCrest-4FSK FEC ON/Scrambling ON) (option 1)
 - PacCrest-4FSK FEC OFF/Scrambling ON) (option 23)
 - PacCrest-4FSK FEC OFF/Scrambling OFF) (option 26)
 - PacCrest-4FSK FEC ON/Scrambling OFF) (option 28)
 - PacCrest-GMSK FEC ON/Scrambling ON) (option 2)
 - PacCrest-GMSK FEC OFF/Scrambling ON) (option 24)
 - PacCrest-GMSK FEC OFF/Scrambling OFF) (option 27)
 - PacCrest-GMSK FEC ON/Scrambling OFF) (option 29)
 - PacCrest-FST 4FSK/FEC ON) (option 5)
 - PacCrest-FST 4FSK/FEC OFF) (option 25)
 - PacCrest-GMSK FEC ON, Scrambling ON, 4800 bps, 25 kHz) (option 16)
 - PacCrest-GMSK FEC OFF, Scrambling ON, 4800 bps, 25 kHz) (option 17)
 - PacCrest-GMSK FEC OFF, Scrambler OFF, 4800 bps, 25 kHz) (option 18)
 - PacCrest-GMSK FEC ON, Scrambler OFF, 4800 bps, 25 kHz) (option 19)
- Trimble compatible modes:
 - TrimTalk450s(P) GMSK, Rx fitted to PacCrest transmitters) (option 3)
 - TrimTalk450s(T) GMSK, Rx fitted to Trimble transmitters) (option 4)
 - TrimTalk v1, GMSK, 8/16 kbps) (option 30)
 - TrimTalk 4800 bps, 25 kHz) (option 31)
- SOUTH (option 8)
- RTCM SC135 modes – these are based on RTCM (Radio Technical Commission for Maritime Services) standard 13500.1 on Radio Layer for Real-Time DGNSS Applications.
 - RTCM SC135 1 (25 kHz, FEC ON) (option 34)
 - RTCM SC135 2 (12.5 kHz, FEC ON) (option 35)
 - RTCM SC135 3 (25 kHz, FEC OFF) (option 36)
 - RTCM SC135 4 (12.5 kHz FEC OFF) (option 37)

Notes:

- Supported compatibility options may vary depending on the model and factory configuration.
- All radio modems of a system must have identical FEC (ON or OFF) and Scrambling (ON or OFF) settings.
- The implementation of the non-native radio compatibility options is based on the reference measurements and the available public data of the following radio modems manufactured by Pacific Crest Corporation: ADL, RFM96W, PDL HPB, PDL LPB.
- TRIMTALK is a trademark of Trimble Navigation Ltd.
- SOUTH is a trademark of SOUTH Surveying & Mapping Instrument Co., Ltd.

The wanted radio compatibility mode can be selected by using:

- SATEL NETCO DEVICE software
- SATEL Configuration Manager software
- SL command SL@S (see chapter *SL commands*)

9.14.1 Settings in Pacific Crest/TRIMTALK compatibility modes

In order to use the Pacific Crest/TRIMTALK modes implemented in SATEL/SATELLINE radios:

PACIFIC CREST modems must have:

- Protocol Mode
- Transparent w/EOT Timeout (when using Pacific Crest modulations)
- TrimTalk 450s (when using TRIMTALK GMSK modulation)
- Modulation Type depends on the system
- GMSK (default, always selected when using TRIMTALK 450s mode)
- 4-Level-FSK
- FEC = ON/OFF
- Scrambling = ON/OFF
- Data Security Code set to = 0 (=not used)
- Local Address= 0...254 (0 by default)

Pacific Crest modems receive messages from SATELLINE modems that have their TX1 address matching the Local Address.

Remote address=0...255 (255 by default, that is the broadcast address to be received by all).

SATELLINE modems receive the message from a Pacific Crest radio, provided their RX1 address matches the Remote Address of a Pacific Crest transmitter (or if the message has the broadcast address 255).

SATELLINE modems must have the following key settings:

- FEC OFF (because the FEC here means SATEL 3AS FEC, not Pacific Crest/TRIMTALK FEC)
- Error check OFF
- Error Check mode OFF
- Radio Compatibility Option according to the list (setting dependent)

When TX address is selected ON, then TX1 address is used like PDL Remote address that is the destination address for the transmitted messages. Default value is 0x00FF (=255) (note the hexadecimal format of the setting).

When RX Address is selected ON, then RX1 address is used like PDL Local address. Default value is 0x0000 (=0) (note the hexadecimal format of the setting).

Addresses are NOT applicable in TRIMTALK 450s mode so SATELLINE modems must have their RX/TX addresses OFF with Option3.

The configuration tools and settings are different between SATELLINE and Pacific Crest modems:

Pacific Crest modems are configured via the serial port using PDLCONF Windows™ program that sends binary control messages to the serial port of the modem.

SATEL radio modems are configured via the serial port using SATEL SW tools or SL commands.

The table below shows the analogy of settings between Pacific Crest and SATEL radio modems.

Pacific Crest setting	Corresponding SATEL setting
Identification: Owner	Not implemented
Identification: Channel Bandwidth	Channel spacing
Identification: RF Power	TX power
Radio Link: Channel Selection Type (Manual)	Radio frequency
Radio Link: Current Channel	Radio frequency
Radio Link: Link Rate	Radio compatibility mode and channel spacing determine the link rate
Radio Link: Modulation Mode	Radio compatibility
Radio Link: Scrambling	ON by default
Radio Link: Transmit Retries	Not implemented
Radio Link: TX ACK Timeout	Not implemented
Radio Link: Csma Monitoring	Priority (RX=ON, TX=OFF) Default: TX
Radio Link: AutoBase/AutoRover	Not implemented
Radio Link: Digisquelch	Signal threshold
Radio Link: Forward Error Correction	ON by default Note: SATELLINE-EASy FEC must be OFF!
Radio Link: Local Address (0 by default)	Primary RX address (RX1) (OFF by default)
Radio Link: Remote Address (255 by default)	Primary TX address (TX1) (OFF by default)
Serial Interface: Protocol Mode	Radio compatibility
Serial Interface: BREAK to Command	Not implemented
Serial Interface: Modem Enable: Yes	Not applicable
Serial Interface: Soft Break Enable	Not implemented
Serial Interface: EOT value (in 0.01s units)	Pause length (in serial port byte intervals)
Serial Interface: Digipeater Delay	Not implemented
Serial Interface: Local Node Repeater	Not implemented
Frequency Table	Radio frequency

Data Security Code (must be 0=not used)	Not implemented
Potential conflicts: FEC setting applies only to the SATELLINE-3AS mode, the other radio compatibility modes have their own FEC bindings (although some previous or special firmware versions differ in the way FEC setting is handled - in case of doubt please contact technical support) Pacific Crest Local/Remote addresses are supported in the firmware versions starting from v3.46.3 Error check and Full CRC16 check must be OFF in SATEL modem Message Routing is not supported by Pacific Crest radios SATEL RX/TX addressing does not use ARQ scheme like Pacific Crest radios.	

9.14.2 Repeater function

The implemented Pacific Crest/TRIMTALK modes support also the repeater function. The repeater function is configured either by using the SL commands:

- "SL@M=R" (Repeater ON)
- "SL@M=O" (Repeater OFF)

or by selecting Repeater OFF/ON in the SW tools (SATEL NETCO DEVICE or SATEL Configuration Manager).

Note 1. If error correction is ON (FEC ON) and TRIMTALK mode is activated by using "SL@S=3" command, the firmware automatically switches SATEL FEC OFF temporarily, and turns it back at the mode return.

9.14.3 Support for Local / Remote addresses

If the modem has TX address ON then primary TX address is handled in the same way as Remote address in Pacific Crest PDL modems. The default value is 0x00FF (255 in decimal format) i.e. the broadcast address.

If the modem has RX address ON then primary RX address is handled in the same way as PDL Local address in Pacific Crest PDL modems. The default value is 0x0000 (0 in decimal format). SATEL modem needs to have TX Delay 50ms or more in order to avoid messages from colliding in case it is to be placed in a Pacific Crest system that uses addressing and acknowledging scheme.

In case only broadcast messages are used (like in RTK applications) there is usually no need for TX Delay, except if the transfer delays identical to Pacific Crest modems are preferred – in such cases an appropriate value of TX Delay is 34 ms.

Note1.

SATEL-modems do not support Pacific Crest retransmit/acknowledge scheme. However, that has no effect in RTK applications because they utilize only broadcast messages.

9.14.4 Transmission delays

The typical transfer delays are presented Appendix A. The original SATEL compatibility modes are the fastest modes. In the PacCrest-4FSK, PacCrest-GMSK and Trimtalk450s modes the whole message is first read from the serial port. The end of the message is detected when there is a pause in data. After that data is framed and transmitted over the radio. Likewise the reception is done fully before outputting the message to the serial port.

10 TEST MODES

The radio modem can be switched to a Test Mode in which it will send test messages to the radio channel. Test messages can be utilized for example when directing antennas during system installation. The transmitting radio modem needs only a power supply and an antenna in the test mode but no external terminal device. If the test mode has been set ON, the radio modem starts to transmit test messages immediately after a reset or a power-up. Test messages are treated as normal data at the receiver side.

10.1 Short Block Test

In this test mode the radio modem sends a short test message that is preceded by a consecutive number and terminated by the Carriage Return and Line Feed characters. The test messages are repeated continuously at 1 second intervals. The short block test is suitable for running radio link tests. Reception of data can be monitored using a suitable terminal program.

Example of short data blocks:

```
00 This is a testline of SATELLINE-3AS radio modem  
01 This is a testline of SATELLINE-3AS radio modem
```

10.2 Long Block Test

In this test mode the radio modem transmits a test message continuously for 50 s. After 10 s break the test transmission is started again. The transmission sequence is repeated continuously. The long block test can be used to measure the transmitter output power, standing wave ratio (SWR) of the antenna system or RSSI (Received Signal Strength Indicator) level at the receiver stations. RSSI can be monitored easily on the LCD display of the receiving modem or by using SL command "SL@R?".

Example of a long data blocks:

```
99 This is a long testline of SATELLINE-3AS radio modem  
00 This is a long testline of SATELLINE-3AS radio modem
```

Note1. Remember to set the test mode OFF before starting the normal data transfer.
Note2. The Test -modes are designed to be used in "SATELLINE-3AS" compatibility mode.

11 MECHANICAL DIMENSIONS

The device dimensions in millimetres.

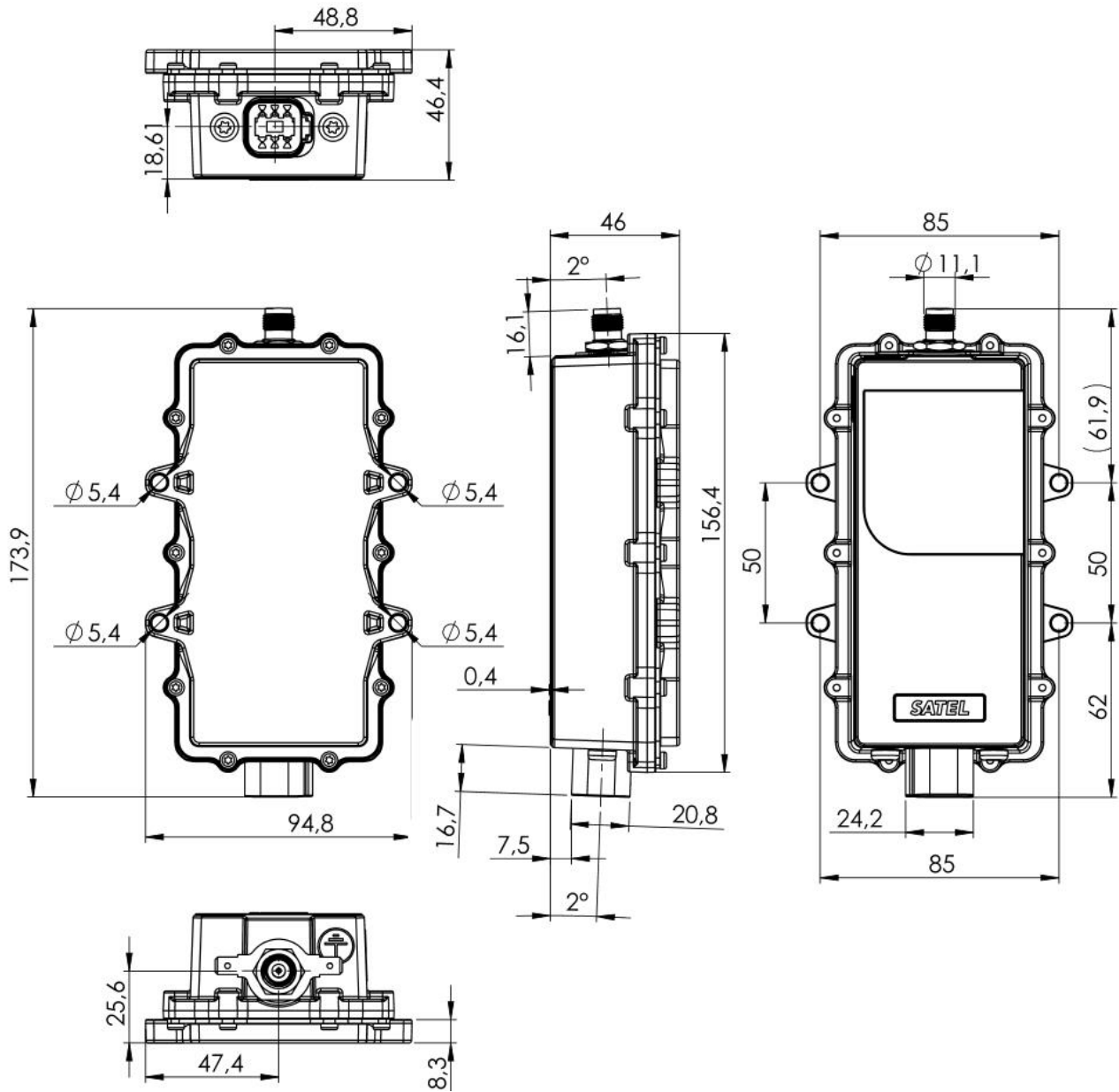

12 INSTALLATION

SATEL Proof radio can be installed to any position from its 4 screw attachment points with maximum of M5 bolts/screws.

SATEL Proof is waterproof fulfilling IP67 and IP69K specifications. Note that the antenna must be installed properly and Deutsch DT connector cable counterpart must have a gasket installed to properly seal the connection in order to reach the IP ratings.

Avoid installations to vibrating surfaces, hot places, directly to sunlight or under water. Avoid abrasion and impacts. Protect the cables and antennas placing them away from damaging elements. Keep the antenna in open space and away from interference.

Antenna is installed either directly to the TNC connector or by using antenna cable. By using a good quality RF-cable and keeping the distance to its shortest will minimize the signal losses.

The following points must be taken into account when installing and configuring a radio modem:

- All operating voltages of all the equipment concerned must always be switched OFF before connecting the serial interface cable.
- To ensure reliable operation the voltage output of the power supply must be stable enough and the current capability of the power supply must be sufficient.
- The antenna must be installed according to instructions.
- Serial interface settings between the radio modem and the terminal unit must correspond to each other.
- All radio modems in the same system must be configured using same radio related settings (radio frequency, channel spacing, etc).
- Check the instructions of grounding the modem on chapter *Grounding*.

NOTE!

The power supply must provide current limiting (FUUSE 1.5A maximum size).

NOTE!

It is not recommended to install the radio modem on a strongly vibrating surface. Suitable dampening and/or isolation materials should be used in cases where the installation surface will be subjected to vibration.

NOTE!

Do not expose the device to solvents or fuels/oils.

13 GROUNDING

SATEL Proof radio modems are equipped with a grounding terminal, as shown below. It is recommended to connect a ground wire from the grounding terminal to the earth ground and that all other interconnected devices share the same electrical ground potential.



Besides the mains voltage safety, proper grounding is essential also for the error free operation of radio links and the protection against over-voltage and lightning. Although SATEL Proof radio modem incorporates a robust internal surge protection, the surge spikes and power transients caused by lightning, ESD or other electrical systems must be discharged to earth ground.

- General installation guidelines for grounding:
- Perform grounding of the system in accordance with local and national regulations.
- Check the grounding related information of other products in the system.
- Use short low impedance cables. Although DC resistance of a ground cable may be a fraction of an ohm, its impedance may be thousands of ohms on the radio frequency. Wide copper straps are the best.
- The ground connection should be connected directly to the power supply, not the ground connection of the load, in order to isolate the radio from voltage drops across the ground return for the load.
- Equipment of the radio system should be grounded in a star ground configuration. The center of the star should be usually connected directly to a good external earth ground scheme.
- The most installations require special measures in the construction of ground electrodes and equipotential bonding – consult professional installation providers.

14 ACCESSORIES

SATEL provides a wide selection of accessories and solutions for its radio modems.

- Antennas
- Serial data/Power cables and adapters
- RF-cables
- Filters and lightning protectors
- Power supplies
- Enclosures

Please visit www.satel.com

15 PROPOSALS FOR MORE RELIABLE RADIO LINK

In case where the environment is challenging the following methods can be used for improving the transmission reliability:

- Forward Error Correction, FEC, is recommended in challenging environment like urban areas.
- Directional antennas.
- Before building the radio link(s) it is highly recommended that the radio environment is measured to find out whether the radio environment is clean enough by using a spectrum analyzer or radio modem's RSSI, Received Signal Strength Indication, value.
- Co-operation with the local authority to find out the optimum free radio channel.
- If the channel is disturbed an external band-pass filter can be used for improving the filtering.
- If at the adjacent channel is TDMA, Time Domain Multiple Access, it is recommended to use time slot for receiving which is not in synchronization with the TDMA radio transmission.
- In Europe it is not recommended to use channels which are located near by the TETRA or television frequencies.

16 APPENDIX A – TRANSMISSION DELAYS

The tables on the next page present the transmission delays vs. the size of the message to be transmitted. The values are in 10% margin.

The delays are measured from the end of transmission to the end of reception on the serial interface as shown below.

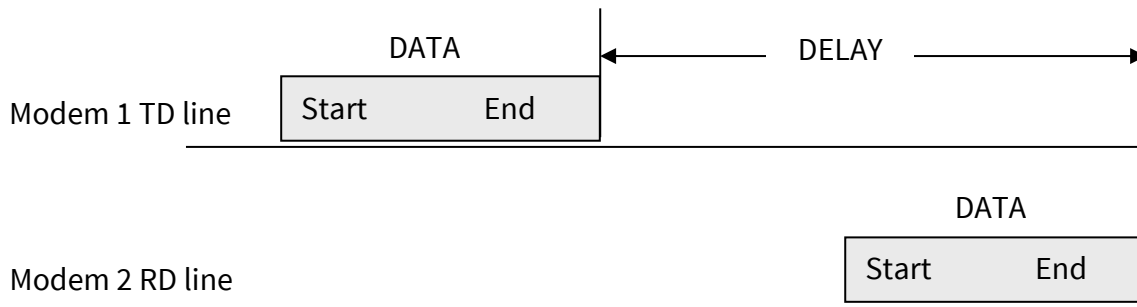

SATELLINE-3AS mode (FEC OFF) on 12.5 kHz channel - Transfer delays				
Bps	1 byte	10 bytes	100 bytes	500 bytes
1200	40 ms	40 ms	29 ms	22 ms
4800	34 ms	34 ms	31 ms	22 ms
9600	32 ms	32 ms	32 ms	27 ms
19200	32 ms	35 ms	64 ms	193 ms
38400	32 ms	36 ms	91 ms	352 ms

SATELLINE-3AS mode (FEC ON) on 12.5 kHz channel - Transfer delays				
Bps	1 byte	10 bytes	100 bytes	500 bytes
1200	52 ms	49 ms	48 ms	50 ms
4800	45 ms	45 ms	44 ms	44 ms
9600	44 ms	44 ms	68 ms	121 ms
19200	44 ms	44 ms	104 ms	360 ms
38400	48 ms	48 ms	132 ms	496 ms

SATELLINE-3AS mode (FEC OFF) on 25 kHz channel - Transfer delays				
Bps	1 byte	10 bytes	100 bytes	500 bytes
1200	30 ms	30 ms	18 ms	16 ms
4800	23 ms	23 ms	21 ms	12 ms
9600	23 ms	23 ms	21 ms	17 ms
19200	22 ms	22 ms	22 ms	19 ms
38400	22 ms	22 ms	38 ms	102 ms

SATELLINE-3AS mode (FEC ON) on 25 kHz channel - Transfer delays				
Bps	1 byte	10 bytes	100 bytes	500 bytes
1200	35 ms	34 ms	29 ms	30 ms
4800	28 ms	28ms	27 ms	23 ms
9600	28 ms	28 ms	28 ms	23 ms
19200	28 ms	28 ms	36 ms	64 ms
38400	27 ms	27 ms	58 ms	185 ms

In the PacCrest-4FSK, PacCrest-GMSK and Trintalk450s modes the whole message is first read from the serial port. The end of the message is detected when there is a pause in data. After that data is framed and transmitted over the radio. Likewise, the reception is done fully before outputting the message to the serial port.

Symbol rates of the compatibility modes		
The actual raw data rate is appr. 2/3 of the symbol rate.		
Compatibility mode	Symbol rate on 12.5 kHz channel	Symbol rate on 25 kHz channel
PacCrest 4FSK	9600 bps	19200 bps
PacCrest GMSK	4800 bps	9600 bps
Trintalk450s	4800 bps	9600 bps
PacCrest FST	9600 bps	19200 bps

The typical latency vs. the size of a message is shown in the tables below for each radio compatibility mode. The delays are measured from the end of transmitted data to the end of received data on the serial interface.

Pacific Crest 4FSK mode on 12.5 kHz channel - Transfer delays				
Bps	1 byte	10 bytes	100 bytes	500 bytes
9600	74 ms	82 ms	302 ms	1293 ms
19200	73 ms	77 ms	249 ms	1031 ms
38400	72 ms	74 ms	222 ms	900 ms

Pacific Crest 4FSK mode on 25 kHz channel - Transfer delays				
Bps	1 byte	10 bytes	100 bytes	500 bytes
9600	43 ms	51 ms	208 ms	911 ms
19200	41 ms	46 ms	155 ms	650 ms
38400	39 ms	43 ms	127 ms	519 ms

Pacific Crest GMSK mode on 12.5 kHz channel - Transfer delays				
Bps	1 byte	10 bytes	100 bytes	500 bytes
9600	93 ms	101 ms	445 ms	2011 ms
19200	91 ms	97 ms	393 ms	1750 ms
38400	91 ms	92 ms	366 ms	1619 ms

Pacific Crest GMSK mode on 25 kHz channel - Transfer delays				
Bps	1 byte	10 bytes	100 bytes	500 bytes
9600	52 ms	62 ms	281 ms	1272 ms
19200	50 ms	55 ms	226 ms	1009 ms
38400	48 ms	51 ms	198 ms	878 ms

Trimtalk450s modes on 12.5 kHz channel - Transfer delays				
Bps	1 byte	10 bytes	100 bytes	500 bytes
9600	153 ms	177 ms	421 ms	1505 ms
19200	151 ms	172 ms	368 ms	1244 ms
38400	151 ms	168 ms	341 ms	1113 ms

Trimtalk450s modes on 25 kHz channel - Transfer delays				
Bps	1 byte	10 bytes	100 bytes	500 bytes
9600	82 ms	98 ms	267 ms	1017 ms
19200	80 ms	93 ms	215 ms	756 ms
38400	79 ms	89 ms	187 ms	625 ms

Radio compatibility Option 5 - Pacific Crest FST on 12.5 kHz channel				
Bps	1 byte	10 bytes	100 bytes	500 bytes
9600	47 ms	71 ms	261 ms	1145 ms
19200	45 ms	64 ms	207 ms	883 ms
38400	48 ms	65 ms	184 ms	756 ms

Radio compatibility Option 5 - Pacific Crest FST on 25 kHz channel				
Bps	1 byte	10 bytes	100 bytes	500 bytes
9600	31 ms	48 ms	190 ms	840 ms
19200	29 ms	41 ms	136 ms	578 ms
38400	28 ms	38 ms	109 ms	447 ms